



TILLAGE EQUIPMENT

Offset Disc » Tandem Discs » Cultivators



VERSATILE
TILLAGE EQUIPMENT
Offset Disc » Tandem Discs » Cultivators

VERSATILE
TILLAGE EQUIPMENT
Offset Disc » Tandem Discs » Cultivators

VERSATILE
TILLAGE EQUIPMENT
Offset Disc » Tandem Discs » Cultivators

VERSATILE TILLAGE

The quality you've come to expect from Versatile is now available in a complete line of tillage. Versatile Tillage has been proven over thousands of acres and more than five decades of breaking land. Designed to meet the needs of farmers and contractors, every piece of Versatile Tillage utilizes an overbuilt and heavy-duty design. Versatile offers a full line of offset and tandem discs, in addition to a line of cultivators, chisel plows and chisel cultivators.





Full Floating Hitch

A floating hitch is important in that it allows the implement to follow irregular ground contours closely. Unlike conventional hitch designs, the floating hitch moves up or down with the tractor without interfering with the operation of the implement. If an obstruction is encountered, the implement simply rolls over it without transferring weight to the front gangs. Blade and bearing damage can be significantly reduced. A spring-cushioned screw crank is provided to make short work of leveling the disc front to rear. Standard on all tandem discs, cultivators, chisel cultivators, chisel plows and model SD1050 offset disc.



410 WSS Series Heavy-Duty Bearings

Exclusive to Versatile the 410 WSS series bearings are an excellent choice for owners looking for a medium to heavy-duty bearing. Rated at 14,100 lb radial load rating, the bearing has seven (7) 15/16" steel ball bearings that are contained within a greaseable housing. The bearing features triple lip seals that cannot be damaged by over-greasing and seal guards protect the seals from rock damage or material wrapping around the gang shaft. The 410 WSS bearing uses a bolt-on cast housing that allows self-alignment which minimizes wear.

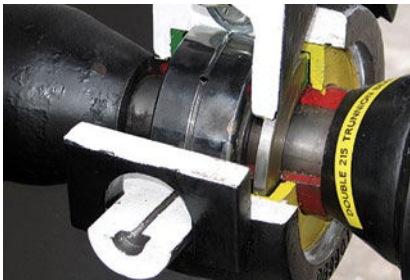

T2-215 Trunnion Mounted Bearings

Exclusive to Versatile the T2-215 series bearings are trunnion mounted to provide positive alignment and handle gang shaft deflection that results from shock loads. Two 215 series ball bearings are positioned back-to-back within the oversized regreaseable housing. Each 215 bearing uses eleven (11) 11/16" steel ball bearings and each T2-215 bearing unit is rated at 22,800 lb radial load rating at 33-1/3 rpm. Housing design makes it simple to remove gangs by removing one bolt per bearing housing.

- » Introduction **2**
- » Offset Disc **4**
 - Model SD550 **5**
 - Model SD650 **5**
 - Model SD1050 **6**
- » Tandem Disc **7**
 - Model TD500 **9**
 - Model TD600 **9**
 - Model TD700 **10**
- » Cultivator **11**
 - Model C500 **13**
 - Model C700 **13**
 - Model C600 **14**
- » Specifications » Offset Disc **16**
- » Specifications » Tandem Disc **17**
- » Specifications » Cultivator Disc **18**
- » Warranty **18**

Versatile is an independent farm equipment manufacturer with a reputation for building reliable, easy to maintain equipment for large producers. Versatile offers a complete range of 4WD tractors, large horsepower row crop tractors, tillage and self propelled sprayers. To learn more about the complete range of Versatile equipment visit www.versatile-ag.com.

OFFSET DISC



Versatile offset discs are available in three weight classes ranging from 550 lb/ft to 1050 lb/ft. Designed to be stronger and last longer Versatile discs feature extreme duty bearings and optional interlocking 1/2 spools and the industry's strongest and tightest gangs with steel fabricated spools torqued to an impressive 3,200 ft-lb.

Features

1. Standard Rigid Hanger - Heavy built rigid hangers hold strong in the most extreme conditions. The SD550 and 1275 use hangers fabricated from solid 1-1/4" high strength steel and clamped onto the gang beam with U-bolts. The SD1050 uses hangers fabricated from rectangular steel tubing. Both hangers have a slim line contour that gives maximum strength combined with excellent trash clearance.

2. Blade Scraper - All Versatile discs feature one piece, 4" wide blade scrapers made of carbon steel for long wear life. The scrapers are U-bolt mounted for maximum adjustment on a heavy-duty tubular steel bar. All scrapers are located high end to the inside of the blade for maximum trash flow and to reduce draft requirements.

3. Adjustable Gang Angle - The cut angle on Versatile offset discs can be adjusted to one of three settings (two on the SD1050) depending on the aggression required. Moisture, soil conditions, residue and trash levels change from season to season and only a disc with an adjustable gang angle will perform well in these varying conditions.

4. Positive Depth Control - A 5-1/2" heavy-duty rockshaft, in greaseable bearings, is the foundation of the single offset disc's depth control system. A single cylinder with positive depth control segments provides consistent and repeatable working depth. An adjustable crank allows the operator to regulate the balance of pressure on both front and rear gangs.



1 Standard Rigid Hanger

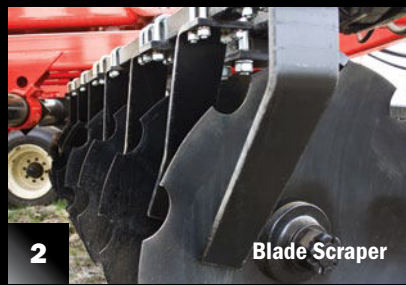

2 Blade Scraper



3 Adjustable Gang Angle



4 Positive Depth Control



5 Removable Spindle Axles



6 Steel Fabricated Spools



7 Large Gauge Shaft



8 Furrow Filler Blades



9 Stone Flex Hanger (option)



10 Pan-Style Scrapers (opt)

5. Removable Spindle Axles - Versatile offset discs are built with maintenance concerns in mind. All spindle axles are designed for easy removal and maximum strength. Each spindle is bolted into a sleeve and can be removed by simply removing the bolt and pulling out the axle. This will save valuable time if repairs to a tire are needed.

6. Steel Fabricated Spools - Versatile discs feature fabricated steel half and full spools. Unlike cast iron spools, steel spools can withstand far greater "shock loads" from rocks or stumps thereby eliminating spool breakage. Compressed to maximum density prior to assembly, Versatile's fabricated spools ensure the gang will not shift and become loose.

7. Large Gauge Shaft - All Versatile discs feature a large 1-15/16" diameter, high carbon steel gang shaft. This gang shaft along with Versatile's steel fabricated spools allows the gang

assembly to be torqued at the factory to 3200 ft/lb.

8. Furrow Filler Blades - In order to get the most uniform and consistent field finish, Versatile offset discs have furrow filler blades as standard equipment. On larger working widths two furrow fillers are standard, one 4" smaller than the working blades and one 8" smaller (only one furrow filler is used on model SD1050). One furrow filler blade that is 4" smaller than the working blades is standard on smaller working widths. These blades along with full sized blades to create a uniform well-worked field.

9. Stone Flex Hanger (option) - For those who want additional protection flex hangers are available as an option. With the extreme thrust forces present on a disc and potential for large rocks in some areas, the stone flex hanger is a perfect choice for absorbing shock loads. The 1-1/4" x 2-1/2" C-shaped

spring steel reacts to both vertical, but more importantly, horizontal forces. Disc blade penetration is not compromised.

10. Pan-Style Scrapers (option) - Available on models SD550 and SD650, pan-style scrapers contact lower down on the disc blade to provide more effective cleaning and prevent sticky soil from building up. As a result, blades cut cleaner and draft is lighter. Scraper material is a boron alloy steel for enhanced wear characteristics. All scrapers are adjustable individually or as a group for optimum field performance.

11. Disc Blades (option) - All Versatile discs feature the latest technology in micro alloy boron steel blades that combine the important performance characteristics of superior ductility - for greater resistance to breakage - with long wearing abrasion resistant hardness.



11 Disc Blades

OFFSET DISC



Model SD550

The Versatile SD550 disc is an all-purpose offset that provides operators the flexibility of a primary or secondary tillage piece. The SD550 is available in 9" or 10.5" spacing and allows operators to manage corn stalks and heavy residue, as well as, break hay fields and heavy pasture. The SD550 can also prepare a smooth seed bed for planting.



1. Frame - The all-welded frame is constructed of 6" x 4" x 3/8" (152 x 102 x 9.5 mm) high tensile tubing. **2. Adjustable Gang Angle** - 3 angles adjustment, 19° for light work 22° for standard and 25° for most aggressive discing action. **3. Blades** - 24", 26", 28" (610, 660, 711 mm) available in notched and smooth.



Model SD650

The model SD650 Versatile offset is an excellent primary tillage tool. Designed for forage breaking and heavy residue this disc is perfect for all agricultural applications and light industrial work. The SD650 is available in working widths from 6' to 20' and 10.5" or 12" blade spacings.

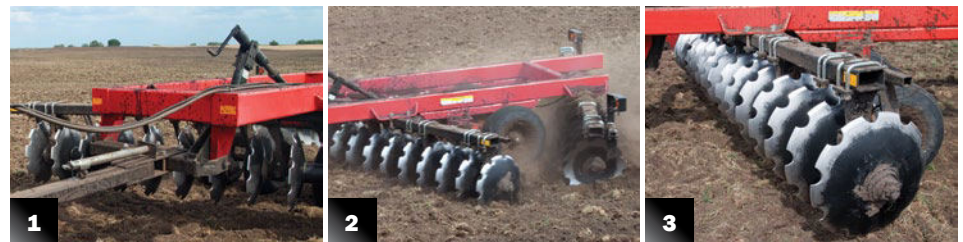

1. Frame - The all-welded frame is constructed of 8" x 4" x 3/8" (203 x 102 x 9.5 mm) high tensile tubing. **2. Adjustable Gang Angle** - 3 angles adjustment, 19° for light work 22° for standard and 25° for most aggressive discing action. **3. Keyed Gangshaft** - ensures a positive locking engagement for the complete gang assembly. Optional on 28" and 30" blades.



Model SD1050

The SD1050 from is a heavy-duty disc designed for heavy construction and mining applications and the most demanding agricultural jobs. The SD1050 features a floating hitch to ensure a smooth level finish on all jobs. Available in 9-1/2 to 15-1/2' widths the SD1050 comes with a standard 14" blade spacing.

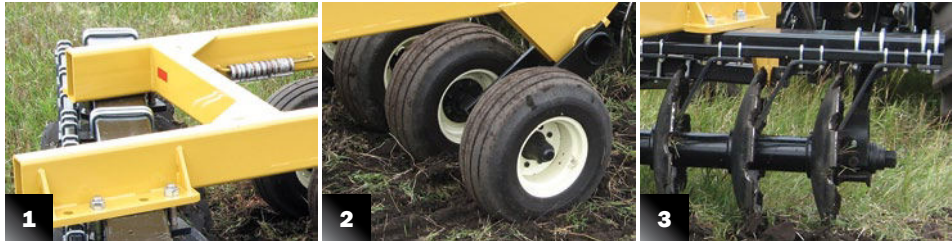

1. Heavy-Duty Frame - both main and wing frames are all-welded, entirely of 10" x 4" x .50" wall tubing. **2. Tires** - For added flotation, 12.5L x 15 FI tires are ideal for severe ground conditions, repeated and prolonged road travel or additional flotation. **3. Heavy-Duty Main Frame Rockshaft** - Constructed of 6-5/8" diameter heavy wall tubing, the rockshaft rotates freely in three greaseable graphite-plastic bearing saddles designed to eliminate metal to metal wear points.

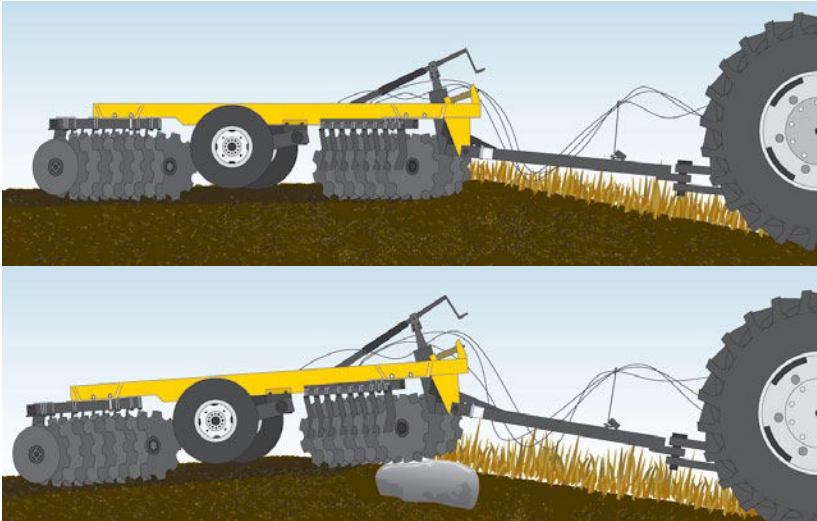

Full Floating Hitch

This feature is standard on the heavier SD1050 model disc and is not available on competitive discs. A floating hitch is important in that it allows the disc to follow irregular ground contours closely. Unlike conventional hitch designs, the floating hitch moves up or down with the tractor without interfering with the operation of the disc. If an obstruction is encountered, the disc simply rolls over it without transferring weight to the front gangs. Blade and bearing damage can be significantly reduced. A spring-cushioned screw crank is provided to make short work of leveling the disc front to rear.

TANDEM DISC



Versatile tandem discs are built to handle trash and incorporate heavy residue. Utilizing a one of a kind floating hitch, Versatile tandem discs leave a more level finish when compared to competitive units. All Versatile disc gangs are torqued to an unparalleled 3,200 ft-lb of torque. Steel fabricated spools are built to withstand heavy shock loads and prevent gangs from slipping. Versatile discs are also built using the best bearings in the industry, so you stay in the field until the job is done.

Features

1. Standard Rigid Hanger - Heavy built rigid hangers hold strong in the most extreme conditions. The slimline hanger is contoured for maximum trash clearance. The TD500N and TD500 hangers are formed 5/8" steel, reinforced for additional strength. The TD600, TD600F, TD700 and TD700F use hangers constructed from 1-1/4" x 5" steel. All hangers are U-bolt mounted to the gang beam for ease of adjustment or removal.

2. Blade Scraper - All Versatile discs feature one piece, 4" wide blade scrapers made of carbon steel for long wear life. The scrapers are U-bolt mounted for maximum adjustment on a heavy-duty tubular steel bar. The leading edge of each scraper is located near the center of the blade for maximum trash flow and to reduce draft requirements. This eliminates the need for trash guards.

3. Transport - Standard hydraulic lock-out valves prevent accidental operation of either the lift or wing cylinders when the disc is being transported. Low transport fold models TD600F and TD700F have a transport height of 13' 11" (4.3 m) and 13' 8" (4.2 m) respectively.

4. Staggered Front Gangs - Staggered, overlapping front gangs are standard and ensure that all soil at the center of

the disc is cut out cleanly and evenly. Besides leaving a more level soil profile, this feature eliminates the need for a center shank or bulk buster normally supplied on most conventional tandems.

5. Removable Spindle Axles - Versatile tandem discs are built with maintenance concerns in mind. All spindle axles are designed for easy removal and maximum strength. Each spindle



1 Standard Rigid Hanger

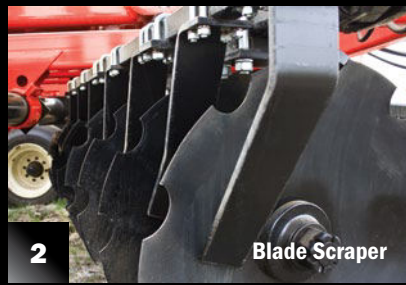

2 Blade Scraper



3 Transport



4 Staggered Front Gangs



5 Removable Spindle Axles



6 Steel Fabricated Spools



7 Furrow Filler Blades



8 Rephasing Hydraulic Lift System



9 Stone Flex Hanger (option)



10 Tandem Walking Beam Axle

is bolted into a sleeve and can be removed by simply removing the bolt and pulling out the axle. This will save valuable time if repairs to a tire are needed.

6. Steel Fabricated Spools - Versatile discs feature fabricated steel half and full spools. Unlike ductile cast spools, steel spools can withstand far greater "shock loads" from rocks or stumps thereby eliminating spool breakage. Compressed to maximum density prior to assembly, Versatile's fabricated spools ensure the gang will not shift and become loose.

7. Furrow Filler Blades - In order to get the most uniform and consistent field finish, Versatile tandem discs have furrow filler blades as standard equipment. The first are 4" smaller than the working blades and the second set are 8" smaller. These blades work with the full sized blades to create a uniform well-worked field.

8. Rephasing Hydraulic Lift System - Depth stop segments are supplied with each disc to ensure continuous same-depth tilling. Each of the wing frames can be easily leveled using a conveniently located eye-bolt adjustment. Cylinder arms on each of the rockshafts are equipped with replaceable hardened wear bushings for prolonged trouble free performance.

9. Stone Flex Hanger (option) - For those who want additional protection, stone flex hangers are available as an option. With the extreme thrust forces present on a disc and potential for large rocks in some areas, the stone flex hanger is a perfect choice for absorbing shock loads. The C-shaped spring steel reacts to both vertical horizontal forces. Disc blade penetration is not compromised.

10. Tandem Walking Beam Axle - Standard on the TD500, TD600, TD600F, TD700 and TD700F. Each

walking beam pivots on two tapered roller bearings to improve weight distribution and stability when being transported.

11. Large Gang Shaft - All Versatile discs feature a large 1-15/16" diameter, high carbon steel gang shaft. This gang shaft along with Versatile's steel fabricated spools allows the gang assembly to be torqued at the factory to 3200 ft/lb.

12. Interlocking Half Spool - This exclusive Versatile feature ensures that each bearing sleeve interlocks with adjoining half spools to provide positive drive to blades and reduces possibility of blades turing on the gang shaft. Optional with 26" blades, standard with 28" and larger (available on 10.5" and 12" spacing only).



11 Large Gang Shaft

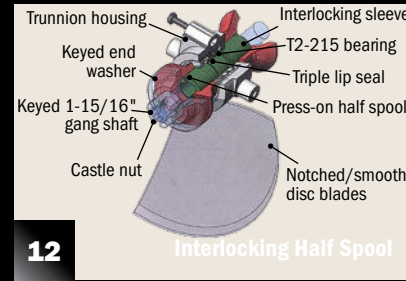

12 Interlocking Half Spool

TANDEM DISC



Model TD500

The Versatile TD500 is a multi-purpose disc with the ability to do primary tillage or to prepare a smooth seed bed. Available in 8" and 9" (203, 230 mm) spacing the TD500 range in working widths from 18' to 40.5' (5.5 to 12.3 m). The Versatile full floating hitch puts the TD500 in a class of their own.



1. Frame - The rugged all-welded frame is constructed of 4" x 4" high tensile tubing. Fore/aft beams on both the main and wide wing frames are doubled for additional strength. **2. Forward-action Wheel Legs** - Located on the wings and promote a level field finish by reducing ridging or gouging in the field. **3. Tires** - 11 L x 15 tires are standard.



Model TD600

The Versatile TD600 and TD600F provide maximum ground penetration and unparalleled trash handling abilities. Featuring the industry's heaviest bearings and steel fabricated spools the TD600 and TD600F are built to stand up in all conditions. A full floating hitch maximizes the functionality of the disc. The TD600F model features a transport height below 14' (4.3 m).



1. Frame - Welded, 6" x 4" (152 x 102 mm) tubular steel frame. **2. Main frame rockshaft** - Constructed of 5.5" (140 mm) diameter heavy wall tubing, the rockshaft rotates freely in greaseable bearing saddles. **3. Forward-action wheel legs** - on the wings promote a level field finish by reducing ridging or gouging. This provides consistent penetration of discing depth in rough field conditions with no need for front gauge wheels.



Model TD700

The Versatile TD700 and TD700F were built to manage heavy residue in corn, stubble and beets or to turn pasture or hay fields. With gangs torqued to 3200 ft-lb and T2-215 bearings the TD700 will withstand almost anything. A full floating hitch creates a smooth level finish and prevents gouging. The TD700F folds to a transport height of just 13' 8".



1. Heavy-Duty Frame - both main and wing frames are all-welded, entirely of 8" x 4" x 0.375 wall tubing. **2. Tires** - For added flotation, 15.0/55-17, 18 PR Alliance tires are ideal for severe ground conditions, repeated and prolonged road travel or additional flotation. **3. Heavy-Duty Main frame Rockshaft** - Constructed of 6-5/8" diameter heavy wall tubing, the rockshaft rotates freely in three greaseable graphite-plastic bearing saddles designed to eliminate metal to metal wear points.

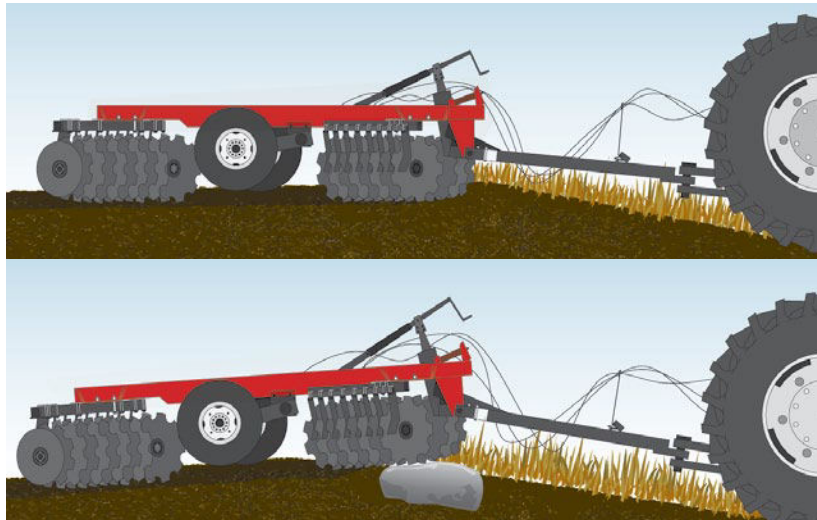

Full Floating Hitch

This feature is standard on all tandem disc models and is not available on competitive discs. A floating hitch is important in that it allows the disc to follow irregular ground contours closely. Unlike conventional hitch designs, the floating hitch moves up or down with the tractor without interfering with the operation of the disc. If an obstruction is encountered, the disc simply rolls over it without transferring weight to the front gangs. Blade and bearing damage can be significantly reduced. A spring-cushioned screw crank is provided to make short work of leveling the disc front to rear.

CULTIVATOR » CHISEL PLOW



Versatile cultivators, chisel plows, and chisel cultivators feature a full floating hitch to maintain a constant working depth. Available with trip force of 350, 550, 600 and 650 lb (159, 250, 272, 295 kg) and in working widths from 23' 6" to 60' (7.2 m to 18.3 m) there is a Versatile cultivator to meet the needs of every operation.

Features

1. Single Cylinder Depth Control - Single cylinder depth control guarantees accurate depth control, achieved by eliminating the leakage that occurs between hydraulic cylinders in series. The result is dependable accuracy in the field where it counts. Standard on models C500 and C700.

2. Quick Wing Levelers - To ensure accurate depth is achieved, the levelness of the toolbar is crucial. Versatile has designed their cultivators so that a single person can level the wing sections side to side by extending or contracting these quick wing levelers.

3. Castor Wheels - The castering axle rides on a nylon graphite wear washer for long life and smooth castering.

Fork style front casters tend to plug with mud and trash build up due to limited space between the tires and each piece supporting it. The Versatile L-shaped caster reduces this problem by 50% and allows for easy removal of wheel and tire if required.

4. Tandem Walking Axles - Tandem walking beams are standard on all Versatile tillage equipment. Each walk-

ing beam pivots on two tapered roller bearings to improve weight distribution and stability when unit is being towed.

5. Front to Rear Leveling - Front to rear leveling is accomplished quickly and easily with adjustable pusharms connected to the rockshaft.

6. Wheel Hub Seals - Protecting wheel bearings in a dust filled environment can be a challenging task. Versatile's



1

Single Cylinder Depth Control



2

Quick Wing Levelers



3

Castor Wheels



4

Tandem Walking Axles



5

Front to Rear Leveling



6

Wheel Hub Seals



7

Mounted Packers (option)



8

Flex-Wing Hinges



9

Mounted Harrows



10

Shank Assembly

hub sealing system is designed specifically for this situation. A triple lip seal is fixed to the spindle, while the seal cup positioned in the hub turns. The result is a longer life of operation and the ability to grease without pushing the seal out.

7. Mounted Packers (option) - available option for all sizes and spacings of C600 Series Chisel/Cultivators. Packer wheels are 20" diameter molded polyethylene construction. Each gang is designed to oscillate on a central pivot ensuring easy obstruction rollover. Packer gangs can be easily removed and replaced with tine harrows should the need arise.

8. Flex-Wing Hinges - A flex-wing hinge system gives the fore / aft travel needed to follow the ground and reduce torsional stress without any maintenance required. The fixed hinge on the second row of each section provides weight transfer from frame to frame to ensure proper depth penetration by each frame section.

9. Mounted Harrows - All models are available with optional 3 or 4 bar mounted harrows for a uniform field finish. Single or double arms mount harrow to cultivator frame. Tines are 3/8" x 18" long, spring steel with 6 position angle adjustment.

10. Shank Assembly - The rugged, spring cushion shank is 3.5" (89 mm) full width nylon-graphite bushing. Self lubricating, these bushings have a long service life with no maintenance required. Shank assemblies have dual springs with a choice of 350 lb (159 kg) or 550 lb (250 kg) initial breakout force.

11. Transport - the wheel base increases when the machine is in transport to provide better stability. This feature is especially important if the cultivator or chisel plow is equipped with mounted harrows or packers.



11

Transport

CULTIVATOR » CHISEL PLOW



Model C500

The Versatile C500 cultivator has a heavy dual spring trip assemblies that allow the unit to perform like a chisel plow. The five-row frame allows crop residue to pass through the frame without plugging, which is a challenge for competitive four row units. A full floating hitch and optional 350 lb (175 kg) trip shanks make the C500 stand out from the competition.



1. Working Wheelbase - a narrow frame depth and short wheelbase creates unmatched ground following characteristics. **2. Transport Wheelbase** - the wheelbase increase when the machine is in transport to provide better stability which is especially important if equipped with mounted harrows or packers. **3. 5-Row Frame** - a fully welded 5-row frame design ensures no two shanks are placed closely on the same row or front to back. This reduces plugging from trash residue leaving a smooth field finish.



Model C700

Developed to be a tough, dependable machine that will impress each time it is put into the field. A massive frame strengthened throughout with oversized rockshafts provide the weight and durability necessary to penetrate the toughest soil conditions.



1. Frame Depth - C700 chisel plows are designed with an extra-long frame with 34" (864 mm) of under-frame clearance to achieve unmatched trash & 4-row frame design. **2. Extensions** - bolt-on extension stubs allow for the increase of the working width. **3. Lock-Out Valves** - when in the locked position the wing will not unfold even if a hydraulic lever is moved accidentally.

CULTIVATOR » CHISEL PLOW



Model C600

The Versatile C600 model can be configured for use as either a heavy tillage unit or as part of a seeding system. Available in 8", 10" or 12" (203, 254, 305 mm) spacing with 350, 550 or 600 lb (159, 250, 272 kg) spring cushion shanks, the 6000 model features a rugged 4-row frame, narrow contour depth and excellent crop residue flow.



1. Frame/Full Width Rockshaft - All-welded four row frame constructed of steel tubing; rockshafts are constructed of 5-1/2" (140 mm) O.D. heavy wall steel tubing. **2. Removable Wheel Spindles** - for ease of removal and repair of complete wheel assemblies. **3. Hitch Stabilizers** - prevent fore/aft movement when in transport.

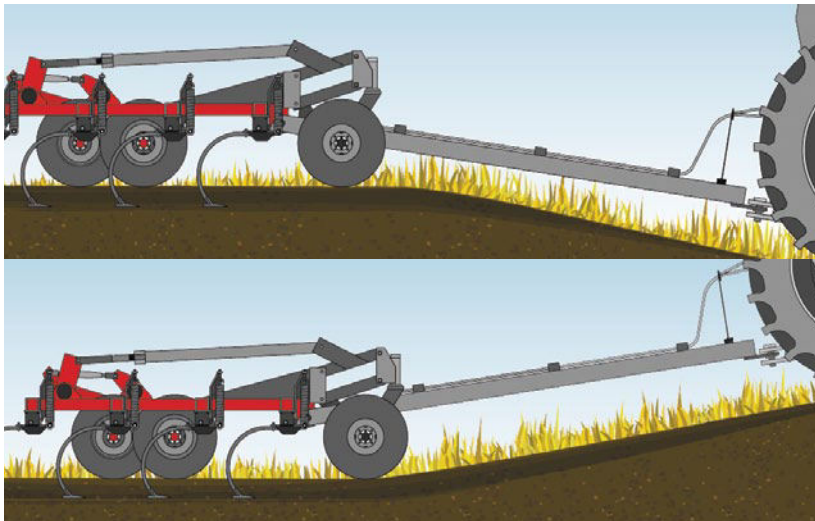

Full Floating Hitch

A floating hitch is important in that it allows the cultivator to follow irregular ground contours closely. Unlike conventional hitch designs, the floating hitch moves up or down with the tractor without interfering with the operation of the implement. If an obstruction is encountered, the implement simply rolls over it without transferring weight to the front gangs. Blade and bearing damage can be significantly reduced. A spring-cushioned screw crank is provided to make short work of leveling the disc front to rear. Standard on all cultivators, chisel cultivators and chisel plows.

SPECIFICATIONS » DISCS

SD550, SD650
Standard Equipment
Hitch jack
Gang wrench socket
Furrow filler blades
4" wide scrapers
1-1/4" bearing hangers (high strength steel)
Safety light kit
Optional Equipment
Bearing wear plates
Safety chain
Gang angle adjustment wrench set
Wide pan scrapers
Stone flex hangers
Clevis hitch

SD1050
Standard Equipment
Full floating hitch
Depth control segments
Tires, 12.5 L x 15
Safety light kit
Optional Equipment
Bearing wear plates
Safety chain

OFFSET DISC MODEL	SD550	SD650	SD1050
Blade Spacing	9" (230 mm)	10.5" (267 mm)	12" (305 mm)
Width, working	6.5' to 20' (1.9 to 6.1 m)	6' to 20' (1.8 to 6.1 m)	6' to 20' (1.8 to 6.1 m)
Width, transport	2.5' (762 mm) wider than working width	2.5' (762 mm) wider than working width	2.5' (762 mm) wider than working width
Weight, per foot	550 lb/ft class (250 kg)	550 lb/ft class (250 kg)	650 lb/ft class (295 kg)
Weight, per blade	242 lb (110 kg)	266 lb (121 kg)	297 lb (135 kg)
Horsepower required*	5 to 6 DBHP/ft	7 to 8 DBHP/ft	7 to 9 DBHP/ft
Structure			
Frame	6" x 4" x 3/8" (152 x 102 x 8 mm)	8" x 4" x 3/8" (203 x 102 x 8 mm)	8" x 4" x 3/8" (203 x 102 x 8 mm)
Gang beam size	6" x 4" x 3/8" (152 x 102 x 8 mm)	6" x 4" x 3/8" (152 x 102 x 8 mm)	6" x 4" x 3/8" (152 x 102 x 8 mm)
Hitch, length	92" (2.33 m)	92" (2.33 m)	92" (2.33 m)
Hanger, std.	Rigid, U-Bolt Mounted	Rigid, U-Bolt Mounted	Rigid, U-Bolt Mounted
Hanger, opt. stone flex	1.25" x 2.5" (32 x 64 mm)	1.25" x 2.5" (32 x 64 mm)	1.25" x 2.5" (32 x 64 mm)
Gang shaft	1-15/16" (49 mm)	1-15/16" (49 mm)	1-15/16" (49 mm)
Spools, steel fabricated	5-1/2" (140 mm) Dia. O.D.	5-1/2" (140 mm) Dia. O.D.	6-5/8" (168 mm) Dia. O.D.
Bearings	410 WSS series	410 WSS / T2-215 series	T2-215 series
Gang angle	25°, 22°, 19° F & R	25°, 22°, 19° F & R	25°, 22°, 19° F & R
Blades			
Blade sizes, notched/smooth	24" x 5/16" (610 x 8 mm)	24" x 5/16" (610 x 8 mm)	26" x 5/16" (660 x 8 mm)
Blade sizes, optional, smooth	24" x 5/16" (610 x 8 mm)	-	-
	26" x 5/16" (660 x 8 mm)	26" x 5/16" (660 x 8 mm)	26" x 3/8" (660 x 9 mm)
Blade sizes, optional, notched/smooth	26" x 5/16" (660 x 8 mm)	26" x 3/8" (660 x 9 mm)	28" x 3/8" (711 x 9 mm)
	-	28" x 3/8" (711 x 9 mm)	30" x 3/8" (762 x 9 mm)
Features			
Adjustable rigid scrapers	4" High Carbon Steel	4" High Carbon Steel	4" High Carbon Steel
Tires	11L x 15 FI	11L x 15 FI	11L x 15 FI
Depth control	Single 4" x 12" (102 x 305 mm) hydraulic cylinder c/w depth control segments		

*Depends on working depth, soil type, field speed, etc.

TANDEM DISC MODEL	TD500N	TD500
Blade Spacing	8" (203 mm)	9" (230 mm)
Width, working*	18' to 32.5' (5.5 to 9.8 m)	35.5' to 40.5' (10.8 to 12.3 m)
Width, transport	12' (3.66 m)	12' (3.66 m)
Height, transport	12' 4" to 16' 11" (3.76 to 5.16 m)	12' 3" to 16' 6" (3.68 to 5.03 m)
Weight	500 lb/ft Class (227 kg)	500 lb/ft Class (227 kg)
Horsepower required †	4.0 to 5.5 DBHP/foot (3.0 to 4.1 kW per 305 mm)	4.0 to 5.5 DBHP/foot (3.0 to 4.1 kW per 305 mm)
Structure		
Frame	Welded, 4" x 4" steel tubing	
Bearings	211 series, opt. 410 WSS series	
Gang angle	20° front / 17° rear	
Gang shaft	1-15/16" (49 mm) high carbon steel torqued to 3200 ft/lb (4339 N.m)	
Blades		
Blades, smooth	22" x 1/4" (560 x 6.5 mm)	22" x 1/4" (560 x 6.5 mm)
Blades, notched/smooth	22" x 9/32" (560 x 7 mm)	22" x 9/32" (560 x 7 mm)
	24" x 9/32" (610 x 7 mm)	24" x 9/32" (610 x 7 mm)
	24" x 5/16" (610 x 8 mm)	24" x 5/16" (610 x 8 mm)
Features		
Tires, main frame	(4) 11L x 15 FI 23.5' to 27' L/R 'D' / (4) 11L x 15 FI 28' to 32.5' L/R 'F'	
Tires, wing frame	(2) 11L x 15 FI 23.5' to 27' L/R 'C' / (4) 11L x 15 FI 28' to 32.5' L/R 'C'	
Depth control	3-cylinder series system c/w depth stop segments	
Hitch	Auto-leveling, full floating hitch	

*w/24" blades † Depends on working depth, soil type, field speed, etc.

SPECIFICATIONS » DISCS

TANDEM DISC MODEL	TD600		TD600F	
Blade Spacing	9" (230 mm)	10.5" (267 mm)	9" (230 mm)	10.5" (267 mm)
Width, working*	26.5' to 35.5' (8.1 to 10.8 m)	25' to 35.5' (7.6 to 10.8 m)	38.5' to 42.0' (11.7 to 12.8 m)	38.5' to 42.0' (11.7 to 12.8 m)
Width, transport	17.5' (5.4 m)	17.5' (5.4 m)	17.5' (5.4 m)	17.5' (5.4 m)
Height, transport	11' 1" to 15' 4" (3.38 to 4.7 m)	10' 7" to 15' 6" (3.3 to 4.7 m)	13' 11" (4.3 m)	13' 11" (4.3 m)
Weight	600 lb/ft Class (261 kg)	600 lb/ft Class (261 kg)	600 lb/ft Class (261 kg)	600 lb/ft Class (261 kg)
Horsepower required †	5.0 to 6.0 DBHP/foot (3.7 to 4.5 kW per 305 mm)	5.0 to 6.0 DBHP/foot (3.7 to 4.5 kW per 305 mm)	5.0 to 6.0 DBHP/foot (3.7 to 4.5 kW per 305 mm)	5.0 to 6.0 DBHP/foot (3.7 to 4.5 kW per 305 mm)
Structure				
Frame	Welded, 6" x 4" (152 x 102 mm) tubular steel frame		Welded, 6" x 4" (152 x 102 mm) tubular steel frame	
Bearings	410 WSS series c/w triple lip seal, opt. T2-215 series		410 WSS series c/w triple lip seal, opt. T2-215 series	
Gang angle	20° front / 17° rear		20° front / 17° rear	
Gang shaft	1-15/16" (49 mm) high carbon steel torqued to 3200 ft/lb (4339 N.m)		1-15/16" (49 mm) high carbon steel torqued to 3200 ft/lb (4339 N.m)	
Blades				
Blade sizes, notched/smooth	22" x 9/32" (559 x 7 mm) 24" x 5/16" (610 x 8 mm) 26" x 5/16" (660 x 8 mm) 26" x 3/8" (660 x 9 mm)	24" x 5/16" (610 x 8 mm) 26" x 5/16" (660 x 8 mm) 26" x 3/8" (660 x 9 mm)	24" x 5/16" (610 x 8 mm) 26" x 5/16" (660 x 8 mm) 26" x 3/8" (660 x 9 mm)	24" x 5/16" (610 x 8 mm) 26" x 5/16" (660 x 8 mm) 26" x 3/8" (660 x 9 mm)
Features				
Tires, main frame	(4) 11 L x 15 FI LR 'F', opt. 12.5 L x 15 FI		(4) 11 L x 15 FI LR 'F', opt. (4) 12.5 L x 15 FI LR 'F'	
Tires, wing frame	(4) 11 L x 15 FI LR 'C', opt. 12.5 L x 15 FI		(4) 11 L x 15 FI LR 'D', opt. (4) 12.5 L x 15 FI LR 'D'	
Depth control	3-cylinder series system c/w depth stop segments		3-cylinder series system c/w depth stop segments	
Hitch	Auto-leveling, full floating hitch		Auto-leveling, full floating hitch	

*w/24" blades † Depends on working depth, soil type, field speed, etc.

TANDEM DISC MODEL	TD700			TD700F	
Blade Spacing	9" (230 mm)	10.5" (267 mm)	12" (305 mm)	10.5" (267 mm)	12" (305 mm)
Width, working*	24.5' to 41.5' (7.5 to 12.6 m)	25.0' to 42.5' (7.6 to 13.0 m)	24.0' to 42.5' (7.3 to 13.0 m)	37.0' to 42.0' (11.3 to 12.8 m)	38.5' to 42.5' (11.7 to 13.0 m)
Width, transport	17.5' (5.4 m)	17.5' (5.4 m)	17.5' (5.4 m)	17.5' (5.4 m)	17.5' (5.4 m)
Height, transport	12' 3" to 18' 5" (3.73 to 5.61 m)	12' 7" to 19' 1" (3.84 to 5.82 m)	12' 7" to 19' 1" (3.84 to 5.82 m)	13' 8" (4.2 m)	13' 8" (4.2 m)
Weight	700 lb/ft Class (318 kg)	700 lb/ft Class (318 kg)	700 lb/ft Class (318 kg)	700 lb/ft Class (318 kg)	700 lb/ft Class (318 kg)
Horsepower required †	7.0 to 8.0 DBHP/foot (5.2 to 6 kW per 305 mm)	7.0 to 8.0 DBHP/foot (5.2 to 6 kW per 305 mm)	7.0 to 8.0 DBHP/foot (5.2 to 6 kW per 305 mm)	7.0 to 8.0 DBHP/foot (5.2 to 6 kW per 305 mm)	7.0 to 8.0 DBHP/foot (5.2 to 6 kW per 305 mm)
Structure					
Frame	Welded, 8" x 4" x .375 wall tubing (203 x 102 x 9.5 mm) tubular steel frame				
Bearings	T2-215 series trunnion mounted bearings				
Gang angle	21° front / 19° rear				
Gang shaft	1-15/16" (49 mm) high carbon steel torqued to 3200 ft/lb (4339 N.m)				
Blades					
Blade sizes, notched/smooth	24" x 5/16" (610 x 8 mm) 26" x 5/16" (660 x 8 mm) 26" x 3/8" (660 x 9 mm)	26" x 5/16" (660 x 8 mm) 26" x 3/8" (660 x 9 mm) 28" x 3/8" (711 x 9 mm)	26" x 5/16" (660 x 8 mm) 26" x 3/8" (660 x 9 mm) 28" x 3/8" (711 x 9 mm) 30" x 3/8" (762 x 9 mm)	26" x 5/16" (660 x 8 mm) 26" x 3/8" (660 x 9 mm) 28" x 3/8" (711 x 9 mm) 30" x 3/8" (762 x 9 mm)	26" x 5/16" (660 x 8 mm) 26" x 3/8" (660 x 9 mm) 28" x 3/8" (711 x 9 mm) 30" x 3/8" (762 x 9 mm)
Features					
Tires, main frame	(4) 12.5 L x 15 FI, 28' to 42.5' - L/R 'F', opt. (4) 15.0 / 55-18 PR			(4) 15.0 / 55-18 PR	
Tires, wing frame	(4) 12.5 L x 15 FI, 28' to 42.5' - L/R 'D', opt. (4) 15.0 / 55-18 PR			(4) 15.0 / 55-18 PR	
Depth control	3-cylinder series system c/w depth stop segments			3-cylinder series system c/w depth stop segments	
Hitch	Auto-leveling, full floating hitch			Auto-leveling, full floating hitch	

* TD700 w/24" blades / TD700F w/28" blades † Depends on working depth, soil type, field speed, etc.

TD500
Standard Equipment
Full floating hitch
Rigid hangers
4" (102 mm) wide scrapers
Furrow leveling blades (4)
Steel spools
Hydraulic transport lockups
Gang socket
Hitch jack
Safety lights
Optional Equipment
Safety chain
Stone flex hangers
Mounted harrows (3-bar)

TD600, TD600F, TD700, TD700F
Standard Equipment
Full floating hitch
Rigid hangers
4" (102 mm) wide scrapers
Furrow leveling blades (4)
Steel spools
Hydraulic transport lockups
Gang socket
Hitch jack
Safety lights
Optional Equipment
Safety chain
Stone flex hangers
Bearing wear plates
Heavy-duty scrapers
Wide pan scrapers
Interlocking half spools
Mounted harrows (3-bar)
Bearing trash guard

SPECIFICATIONS » CULTIVATOR

C500	
Standard Equipment	Optional Equipment
Full floating hitch	Safety chain
Safety light kit	Mounted harrows
Depth control segments	Mounted packers
	Universal tow hitch
	Spare tire/wheel carrier
	Shank drop kits
	Air distribution kits

C700	
Optional Equipment	
Spare tire/wheel carrier	Mounted packers
Mounted harrows	Mounted packer rock deflectors
Shank drop kits	Mounted packer mud scrapers
Safety chain	Air distribution kits
HD main castor, 8-bolt	Hitch stabilizer kit
Universal tow hitch	

MODEL	C500		C700	
Sections	3	3	3	3
Main frame, type	Narrow	Wide	Narrow	Wide
Width, main frame	13' 6" (4.1 m)	16' (4.9 m)	14' (4.3 m)	16' (4.9 m)
Width, working	23' 6" to 40' 2" (7.2 to 12.3 m)	31' 10" to 45' 6" (9.5 to 13.9 m)	26' to 40' (7.9 to 12.2 m)	28' to 44' (8.5 to 13.4 m)
Width, transport	17' 10" (5.4 m)	20' 6" (6.2 m)	18' 9" (5.7 m)	20' 9" (6.3 m)
Height, transport	9' 8" to 18' 10" (2.9 to 5.7 m)	9' 8" to 18' 10" (2.9 to 5.7 m)	11' 0" to 17' 10" (3.4 to 5.4 m)	11' 0" to 17' 10" (3.4 to 5.4 m)
Weight (less harrows)	10,538 to 14,626 lb (4780 to 6634 kg)	10,538 to 14,626 lb (4780 to 6634 kg)	10,940 to 14,029 lb (4962 to 6364 kg)	10,940 to 14,029 lb (4962 to 6364 kg)
Structure				
Frame, design	5 rows	5 rows	4 rows	4 rows
Frame, depth	98" (2.5 m)	98" (2.5 m)	98" (2.5 m)	98" (2.5 m)
Frame, members	4" x 4" (102 x 102 mm) welded	4" x 4" (102 x 102 mm) welded	4" x 4" (102 x 102 mm) welded	4" x 4" (102 x 102 mm) welded
Under frame clearance	Minimum 27" (686 mm)	Minimum 27" (686 mm)	Minimum 34" (864 mm)	Minimum 34" (864 mm)
Floating hitch	Standard	Standard	Standard	Standard
Operation				
Operating depth	Adjustable up to 8" (203 mm) of working depth	Adjustable up to 8" (203 mm) of working depth	Adjustable up to 8" (203 mm) of working depth	Adjustable up to 8" (203 mm) of working depth
Operating speed	5 to 7 mph (8 to 11.25 km/hr)	5 to 7 mph (8 to 11.25 km/hr)	5 to 7 mph (8 to 11.25 km/hr)	5 to 7 mph (8 to 11.25 km/hr)
Contour depth	85.5" (2.2 m)	85.5" (2.2 m)	85.5" (2.2 m)	85.5" (2.2 m)
Flexibility	14.5° up, 8° down c/w fore/aft ability	14.5° up, 8° down c/w fore/aft ability	14.5° up, 8° down	14.5° up, 8° down
Shanks				
Shank spacing	8" or 10" (203 x 254 mm)	8" or 10" (203 x 254 mm)	12" (305 mm)	12" (305 mm)
Shanks, std	550 lb (250 kg) dual spring cushion	550 lb (250 kg) dual spring cushion	650 lb (295 kg) dual spring cushion	650 lb (295 kg) dual spring cushion
Shanks, opt	350 lb (159 kg) dual spring cushion	350 lb (159 kg) dual spring cushion 3.5"	-	-
Shank pivot bushing	3.5" (89 mm) nylon-graphite	(89 mm) nylon-graphite	5" (127 mm) nylon-graphite	5" (127 mm) nylon-graphite
Features				
Trip height	13" (330 mm)	13" (330 mm)	12" (330 mm)	12" (330 mm)
Tires, main frame	11L x 15 (5)	11L x 15 (5)	11L x 15 (5)	11L x 15 (5)
Tires, wing	11L x 15 (3)	11L x 15 (3)	11L x 15 (3)	11L x 15 (3)
Depth control	Single 5" x 12" (127 x 305 mm) cylinder rotates heavy-duty rockshafts to raise or lower the entire implement. Positive mechanical depth stop segments control depth cylinder in 1/8" (3 mm) increments, no rephasing required			

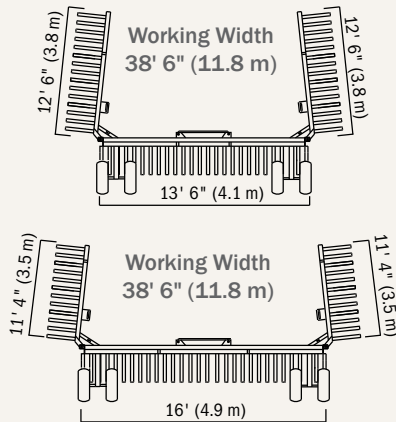

Main Frame - Narrow vs. Wide The same working width can be achieved with both the wide and narrow main frame. So which should you choose?

Why Choose A Narrow Frame?

A narrow frame should be selected when transport width is a concern. This will increase the transport height so this must be considered as well.

Why Choose A Wide Frame?

A wide frame will result in a lower transport height. This configuration should be used when facing low obstacles such as bridges and overpasses. Transport width will be increased.

See your local Versatile Dealer for assistance in determining the ideal configuration for your unique requirements.

SPECIFICATIONS » WARRANTY

MODEL	C600				
Widths	44' (13.4 m)	48' (14.6 m)	52' (15.8 m)	56' (17.0 m)	60' (18.3 m)
Width, transport	20' 6" (6.2 m)	20' 6" (6.2 m)	20' 6" (6.2 m)	20' 6" (6.2 m)	20' 6" (6.2 m)
Height, transport	14' (4.3 m)	16' (4.9 m)	18' (5.5 m)	18' (5.5 m)	18' (5.5 m)
Structure					
Sections	5	5	5	5	5
Frame, design	4 rows	4 rows	4 rows	4 rows	4 rows
Frame, depth	98" (2.5 m)	98" (2.5 m)	98" (2.5 m)	98" (2.5 m)	98" (2.5 m)
Frame, members	High tensile strength 4" x 4" (102 x 102 mm) HSS frame hubing	High tensile strength 4" x 4" (102 x 102 mm) HSS frame hubing	High tensile strength 4" x 4" (102 x 102 mm) HSS frame hubing	High tensile strength 4" x 4" (102 x 102 mm) HSS frame hubing	High tensile strength 4" x 4" (102 x 102 mm) HSS frame hubing
Under frame clearance	Min. 30" (762 mm)	Min. 30" (762 mm)	Min. 30" (762 mm)	Min. 30" (762 mm)	Min. 30" (762 mm)
Contour depth	85.5" (2.2 m)	85.5" (2.2 m)	85.5" (2.2 m)	85.5" (2.2 m)	85.5" (2.2 m)
Floating hitch	19' (5.8 m) length	19' (5.8 m) length	19' (5.8 m) length	19' (5.8 m) length	19' (5.8 m) length
Shanks					
Shank spacing	8", 10", 12" (203, 254, 305 mm)				
Shanks	350 lb (175 kg) spring cushion 7/8" x 2" (22 x 51 mm) tempered steel shank (47°) 550 lb (250 kg) spring cushion 1" x 2" (25 x 51 mm) tempered steel shank (47°) 600 lb (272 kg) spring cushion 1-1/4" x 2" (32 x 51 mm) tempered steel shank (50°)				
Shank pivot bushing	3.5" (89 mm) nylon-graphite				
Features					
Tires, main frame	Axles - 11 L x 15 FI load range F, opt. 12.5 L x 15 / Castors - 11 L x 15 FI load range F, opt. 12.5 L x 15				
Tires, wing	Axles - 11 L x 15 FI load range D, opt. 12.5 L x 15 / Castors - 11 L x 15 FI load range C, opt. 12.5 L x 15				
Depth control	Tandem 4" x 8" (102 x 203 mm) cylinder rotates heavy-duty rockshafts to raise or lower the entire implement Positive mechanical depth stop segments control depth cylinder in 1/8" (3 mm) increments, no rephasing required				

*Depends on working depth, soil type, field speed, etc.

C600	
Standard Equipment	Optional Equipment
Full floating hitch	Safety chain
Safety light kit	Spare tire/wheel carrier
Depth control segments	Mounted harrows
	Mounted packers
	Shank drop kits
	Shank mounted harrows
	Tires, 12.5 L x 15
	Air distribution kits

Three Year Limited Warranty

At the sole discretion of Versatile, defective parts and/or workmanship will be repaired or replaced for the original, non commercial owner. Coverage is: 1-12 months 100% parts and labor, 13-24 months 100 Versatile manufactured parts, 25-36 months 50% Versatile manufactured Parts.

Contact your Versatile dealer or factory for complete warranty details including exclusions to coverage.

Seven Year Limited Warranty

Extended coverage (12 to 84 months) on T2-215 series bearings is limited to the replacement of the ball bearings and seals for the original, non commercial owner. Associated bearing parts, labor, freight, etc. are not covered.

Contact your Versatile dealer or factory for complete warranty details including exclusions to coverage.



Your dealer in Africa and the Middle East:

RAC Export Trading D-36041 Fulda / Germany Tel. +49 661 6060 82

www.rac-germany.com info@rac-export.de

Illustrations, photographs, and specifications in this brochure are based on the latest information at the time of publication. Design and specification of equipment is subject to change without notice; please contact RAC Export Trading for product information and availability. Products produced by other manufacturers featured in photography are not endorsed by Buhler Versatile Inc. and are intended for image reference only.